

Discover®

DEEP CYCLE

AGM Battery



Discover's Deep Cycle AGM batteries were created to meet the needs of today's demanding users, specifically in the challenging world of leisure applications.

Discover Deep Cycle AGM batteries incorporate improvements not commonly seen in these applications.

We set the standard with our robust Polypropylene (PP) case, providing enhanced mechanical and thermal properties. Not only does the case technology offer the advantage of improved heat resistance, it provides the benefit of high chemical resistance, making it ideal for under the bonnet applications. Every Deep Cycle AGM battery from Discover is made with superior plates, complete with intercell welding, not commonly seen with other AGM designs.

Maintenance-free Technology:

No topping up required.

High charge retention. Self discharge rate of less than 2-3% per month (25°C).

Eliminates corrosion due to off-gassing.



CARAVAN ■ CAMPING ■ 4x4 ■ BOATING

SPECIFICATIONS

TYPE NO.	CAPACITY 20 HR	MINUTES OF DISCHARGE		CA	CCA	LENGTH ^A	WIDTH ^B	HEIGHT ^{C*}	WEIGHT KG	TERMINAL
		@ 25A	@ 75A			MM	MM	MM		
12 VOLT DEEP CYCLE AGM BATTERY										
D27A-100D	100	180	43	830	690	308	172	214	29.0	M8
D31A-120D	120	215	55	940	785	330	172	218	33.0	M8

* Height from the bottom of the battery to the highest point of the terminal.

Terminal

M8

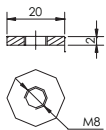

Drawing

D27A-100D

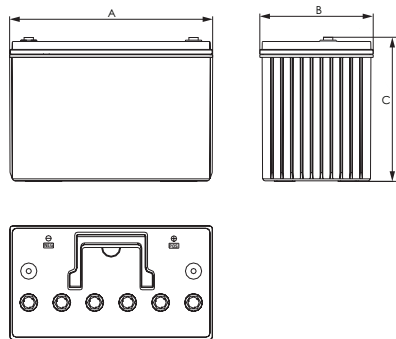

D31A-120D

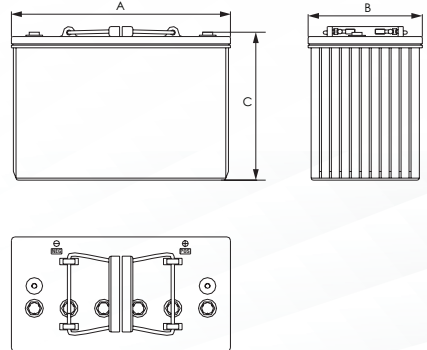

FEATURES & BENEFITS

- High impact reinforced Polypropylene (PP) case with flat top design
- Improved vibration protection
- Suitable for under the bonnet applications
- Superior charge acceptance
- Special grid alloy and paste formula for reduced self-discharge and extended runtime and cycle life performance
- UL924 recognized flame arrestors for improved safety
- Gas recombination technology for zero off gassing
- Stronger and ergonomic moulded carry handles providing improved safety
- Lighter weight from superior case and intercell welding design
- TTP welds (Through the Partition) for lower internal resistance and improved heat resistance

LIFE CHARACTERISTICS IN CYCLIC USE (CYCLIC MODELS ONLY)

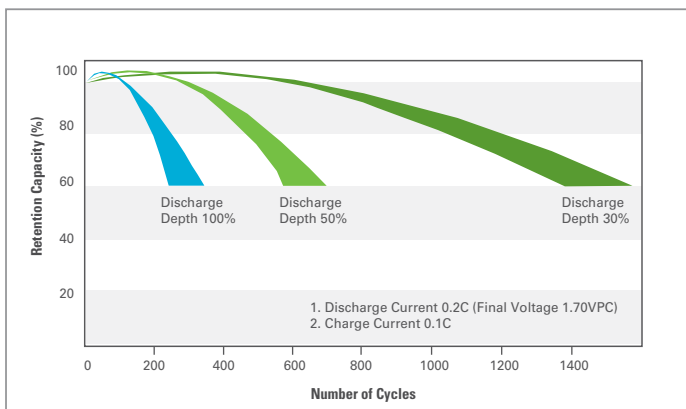

- Classified non-spillable, non-hazardous and exempt from DOT hazardous materials regulations. 49 CFR 173.150(d) compliant.
- Approved for all modes of transportation.
- Certified to ISO, UL and CE quality standards.
- Complaint with IEC standards.

