

**AES BATTERY (12-PIN M12 A-CODE)
MAPPED TO LYNK GATEWAY DEVICES
(5-PIN M12 A-CODE)**

READ AND SAVE THESE INSTRUCTIONS

INTRODUCTION 3

1. AUDIENCE, MESSAGES, WARNINGS, GENERAL SAFETY, PERSONAL PROTECTIVE EQUIPMENT ... 3

1.1 Audience.3

1.2 Warning, Caution, Notice, and Note Messages.3

1.3 General Warnings4

1.4 Safe Handling Procedures.4

1.5 Personal Protective Equipment.5

2. DOCUMENTATION..... 5

3. CONNECTING THE LYNK COMMUNICATION GATEWAY TO THE AES BATTERY 6

3.1 AEBus Port on the AES 14-24-2800, 12-36-6700, and 12-48-6650 batteries 6

3.2 LYNK Port on the LYNK Communication Gateway Device7

3.3 Creating a Cable to Connect the AES Battery and the LYNK Communication Gateway Device8

Introduction

This Application Note provides information about connecting an AES LiFePO₄ battery's 12-pin M12 A-Code AEBus port to a LYNK Communication Gateway device's 5-pin M12 A-Code LYNK port to support communication between batteries and power conversion devices.

1. AUDIENCE, MESSAGES, WARNINGS, GENERAL SAFETY, PERSONAL PROTECTIVE EQUIPMENT

1.1 Audience

Configuration, installation, service, and operating tasks should only be performed by qualified personnel in consultation with local authorities having jurisdiction and authorized dealers. Qualified personnel should have training, knowledge, and experience in the:

- Installation of electrical equipment
- Application of applicable installation codes
- Analyzation and reduction of hazards involved in performing electrical work
- Installation and configuration of batteries
- Installation and configuration of systems activated by relays

1.2 Warning, Caution, Notice, and Note Messages

Messages in this manual are formatted according to this structure.

WARNING

Important information regarding hazardous conditions that may result in personal injury or death.

CAUTION

Important information regarding hazardous conditions that may result in personal injury.

NOTICE

Important information regarding conditions that may damage the equipment but not result in personal injury.

NOTE

Ad hoc information concerning important procedures and features unrelated to personal injury or equipment damage.

1.3 General Warnings

WARNING

ELECTRIC SHOCK AND FIRE HAZARD

- A lithium battery must be installed as specified.
- Do not disassemble or modify the battery.
- If the battery case has been damaged, do not touch exposed contents.
- There are no user-serviceable parts inside.

Failure to follow these instructions may result in death or serious injury.

WARNING

ELECTRIC SHOCK AND FIRE HAZARD

Do not lay tools or other metal parts on the battery or across the terminals.

Failure to follow these instructions may result in death or serious injury.

CAUTION

ELECTRIC SHOCK

- Do not touch the energized surfaces of any electrical component in the battery system.
- Before servicing the battery, follow all procedures to fully de-energize the battery system.
- Follow the “Safe Handling Procedures” below when working with the battery.

Failure to follow these instructions may result in injury.

1.4 Safe Handling Procedures

Before using the battery and any power electronics, please read all instructions and cautionary markings on all components and appropriate sections of their manuals.

- Use personal protective equipment when working with batteries.
- Do not dispose of the battery in a fire.
- Promptly dispose of or recycle used batteries following local regulations.
- Do not disassemble, open, crush, bend, deform, puncture, or shred.
- Do not modify, re-manufacture, or attempt to insert foreign objects into the battery, immerse or expose the battery to water, other liquids, fire, explosion, or other hazards. If the user suspects damage to the battery due to water, heat, or other reason, take it to a service center for inspection.
- Only use the battery for the system for which it is specified.
- Do not lift or carry the battery while in operation.
- When lifting a heavy battery, follow the appropriate standards.
- Only lift, move, or mount following local regulations.
- Take care when handling battery terminals and cabling.
- Only use the battery with a charging system that has been qualified for the system. Using a battery or charger that does not meet specifications may present a risk of fire, explosion, leakage, or other hazards.

- Do not short circuit a battery or allow metallic conductive objects to contact battery terminals.
- Replace the battery only with another one qualified for the system. Using an unqualified battery may present a risk of fire, explosion, leakage, or other hazards.
- Avoid dropping the device or battery. If the device or battery is dropped, especially on a hard surface, and the user suspects damage, take it to a service center for inspection.

1.5 Personal Protective Equipment

When handling or working near a battery:

- Use Personal Protective Equipment, including clothing, glasses, insulated gloves, and boots.
- Do not wear metal rings, watches, bracelets, or necklaces.

2. DOCUMENTATION

This Application Note provides information about connecting the AEBus port (M12 12-pin circular connector) of an AES LiFePO₄ battery to the LYNK Port (M12 5-pin circular connector) of a LYNK Communication Gateway device.

The following information applies to:

- 14-24-2800
- 12-36-6700
- 12-48-6650
- LYNK II Communication Gateway
- LYNK LITE Communication Gateway

Before installation and configuration, consult the relevant product documentation, including Manuals, Application Notes, and Installation and Configuration Guides.

Discover Energy Systems Documentation

Visit discoverlithium.com for the most recent version of published documents, including Discover Lithium battery user manuals, the LYNK II Installation and Operation Manual (805-0033), and LYNK LITE Installation and Operation Manual (805-0035).

3. CONNECTING THE LYNK COMMUNICATION GATEWAY TO THE AES BATTERY

NOTICE

- Turn OFF all devices before connecting cables.
- Do not connect a CAT5 cable from the AEBus, LYNK, or Ethernet ports of LYNK Communication Gateway devices to a WAN or MODEM port of a network router.
- Mixing the LYNK network with other networks may result in equipment malfunction and damage.

NOTICE

Unless Discover Energy Systems specifies, power electronics must not be connected directly to the LYNK or AEBus network.

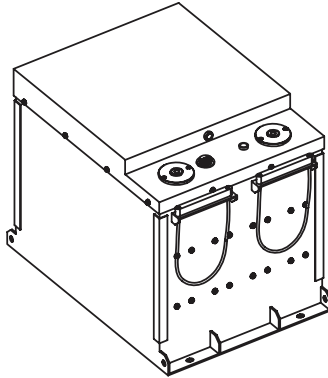

Figure 1. AES LiFePO₄ Battery

3.1 AEBus Port on the AES 14-24-2800, 12-36-6700, and 12-48-6650 batteries

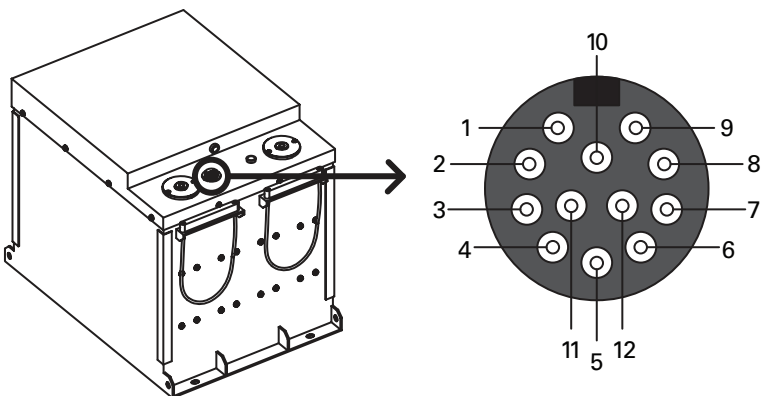

Figure 2. 12-pin M12 A-Code Circular Male Connector

Pin	Description
1	—
2	—
3	AEBus CAN GND
4	AEBus CAN High
5	AEBus CAN Low
6	—
7	—
8	—
9	—
10	—
11	—
12	AEBus CAN +12V ⁽¹⁾

(1) Hardware version 0.0.0.2

3.2 LYNK Port on the LYNK Communication Gateway Device

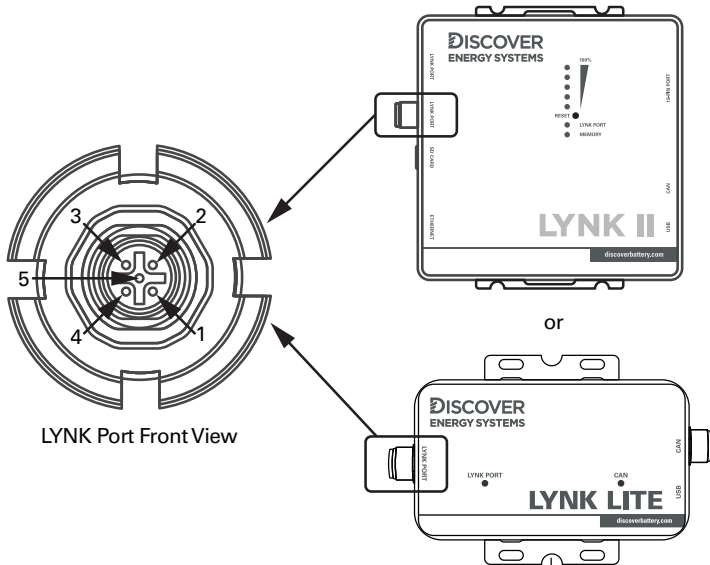

Figure 3. LYNK Communication Gateway 5-pin M12 A-Code Circular Male Connector

Pin	Description
1 (1)	—
2	LYNK Bus CAN Low
3	LYNK Bus CAN High
4	LYNK Bus +12 V
5	LYNK Bus CAN GND

(1) Do not populate. Do not terminate to ground. Do not terminate to power. Do not terminate to CAN L or CAN H.

3.3 Creating a Cable to Connect the AES Battery and the LYNK Communication Gateway Device

As shown in [Figure 4. Cable Wiring Diagram](#), create a cable with M12 A-Code receptacles to wire the pins from the 12-pin M12 A-Code male port on the AES LiFePO₄ battery to the 5-pin M12 A-Code male port on the LYNK Communication Gateway device. Isolate any pins that are not connected in the diagram.

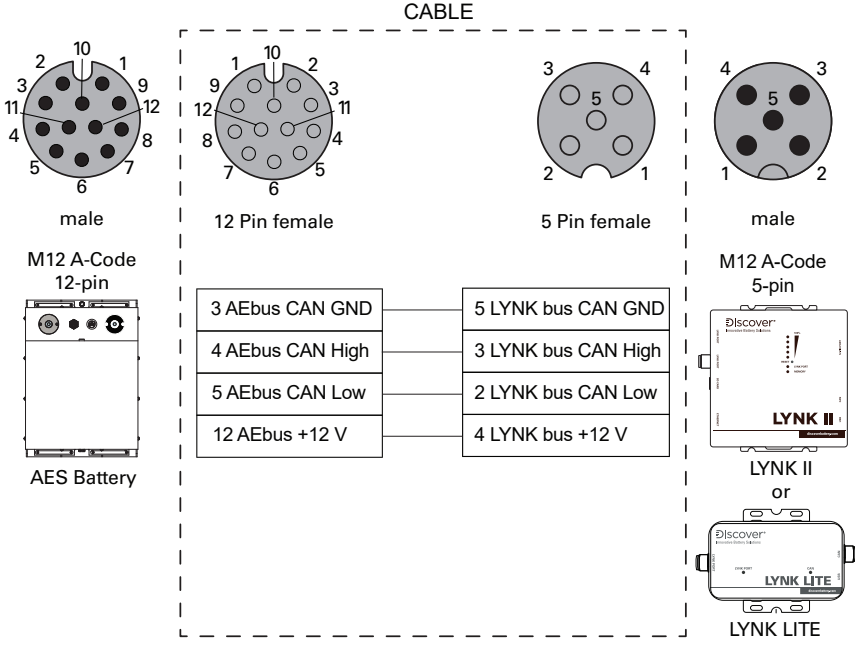

Figure 4. Cable Wiring Diagram