

Construction of Poles - OPzS Cells

OPzS batteries are batteries with an expected service life of 20 years for OPzS cells and 18 years for OPzS blocks. In this period we get in average a corrosion layer of $30\mu\text{m}/\text{year} \times 20\text{years} = 600\mu\text{m}$ or 0,6mm on the positive grid, here around the spines of the tubular plate. As a consequence of the corrosion of the spine we get a growth of the positive plate and the positive pole. To avoid any cracking of lid and container, use of a sliding pole mitigates the situation

The pole is casted with a brass inlay, characterized by a M10 thread for receiving the M10 pole screw. Next a labyrinth is machined in the lead shaft of the pole. This part is covered with a primer prior to the injection-mould to form a plastic jacket. The seal between the lid and the plastic jacket is made by a strong rubber ring, which allows a sliding during growth of the pole. A pole ring in the colors blue for the negative and red for the positive pole covers the black ring and makes the polarity-finding easier.

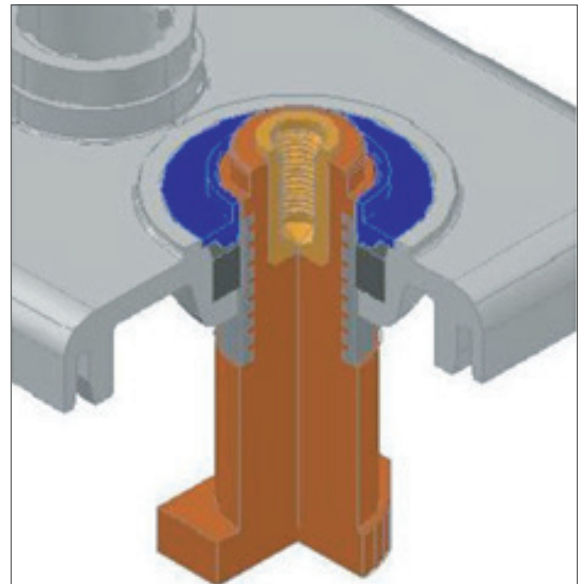
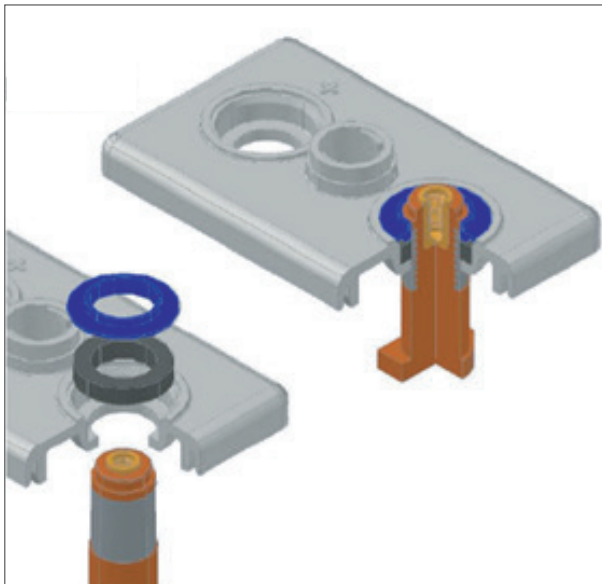

We can see in the drawing that the pole bushing design allows a growth of 12.8mm, before the lead surface touches the lid. It is 4mm more, say 16.8mm before the lead surface touches the lower edge of the black rubber ring. According to our experience the rubber ring stays in place and the pole is moving upwards.

Outside of the cell we provide a 5mm ring of the pole with free access of measuring the contact resistance of the connectors, the impedance value of the cell and f.e. with a crocodile-clamp the cell voltage during a capacity test. The dimension of the pole bushing parts and the connector (here we see a cable connector) are chosen in a way that we get a contact protection IP 25 according to DIN 40050.

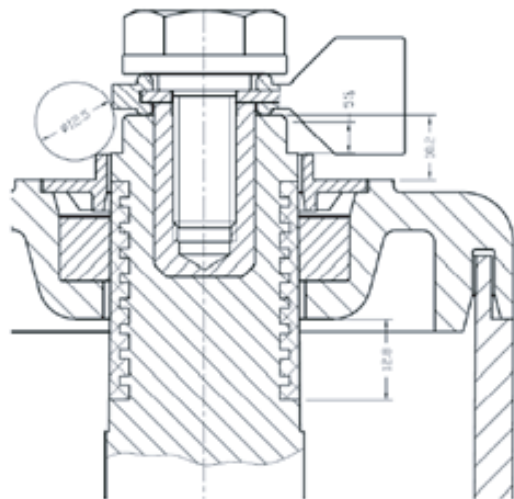

The design is safe against touching with fingers and against water from all directions. The cable connector is pressed onto the pole by a plastic-headed screw with a high torque of 22Nm, providing a good contact and sealing the contact surface with rubber lips from above and below. The plastic-headed screw has on top a lead ball, to measure the cell voltage. Cable connectors can be provided from 35mm² to 180mm² copper cross section. For telecom applications we deliver normally cable connectors with 50 to 70mm² cross section. As option we can deliver flat copper connectors having also the lips by injected Thermo-Plastic-Polymer (TPP).

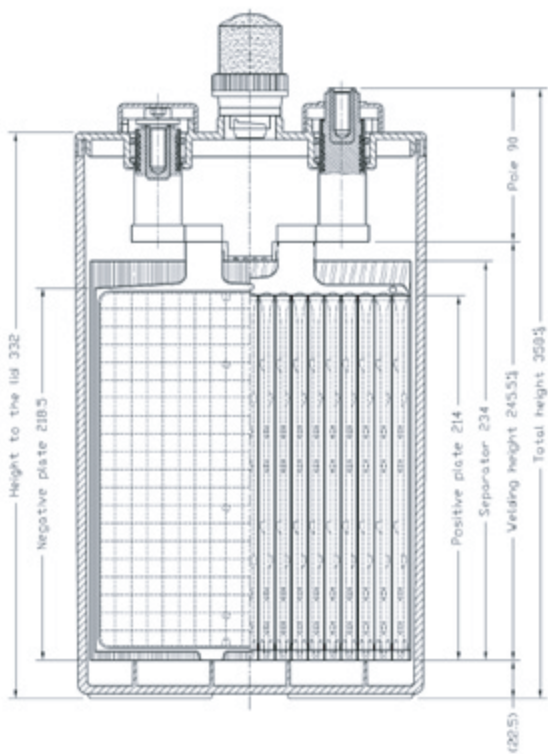

During assembling of OPzS blocks we need the bolted connection only between the end poles. All other poles of a block are also guided through the lid, providing sliding of the pole through the lid.

On top of the lid the poles are connected with copper connectors. The design of the inter-cell connectors provides also a growth of the positive poles. The inter-cell connectors are covered by plastic covers. Holes in it provide voltage measurement of all cells. The end poles are penetrating the plastic protection covers.